

Greenfield

"Excellence through Innovation"

OWNER'S MANUAL

MODEL

L/P/D SLASHER MOWER



INSTRUCTIONS AND SPARE PARTS

Greenfield reserves the right

to change specifications without notice. © 2010 Greenfield Mowers. All rights reserved. Printed in Australia. Greenfield Mowers is a registered trademark of Greenfield Mowers Pty Ltd.

I . P . D . S L A S H E R M O W E R

Greenfield I.P.D.

Slasher Mower

Thank you for buying an Australian made Greenfield mower. Your Greenfield IPD (Industrial Power Drive) slasher mower is built for tough work and is ideal for large lawn mowing or heavy scrub clearing. Follow the manufacturer's operating and maintenance instructions and many years of excellent trouble free service can be expected.

Before operating the mower read the owner's manual carefully. Do not allow children or any person unfamiliar with the safe operating procedure to operate this slasher mower. Your Greenfield mower has been designed to meet stringent safety standards but, we remind you that a mower is a cutting device used incorrectly it could cause personal injury.

Safety Instructions

1. **WARNING – Remove spark plug lead** to avoid accidental starting before attempting any inspection or maintenance on the mower.
2. Do not mow whilst people, especially children or pets are in the mowing area. Children should be kept elsewhere and supervised. Never assume children are where you last saw them.
3. Make sure the area to be mowed is clear of sticks, stones, bones, bottles, wire and other debris that could be thrown by the blades. Never engage the blades without the safety deflector fitted.
4. Do not operate the machine without first inspecting the blades, blade bolts and blade holder for wear or damage. **DAMAGED BLADES AND WORN BOLTS ARE MAJOR HAZARDS.** Always replace blades and blade bolts in sets to preserve balance. Replace worn or damaged parts with **genuine GREENFIELD** replacement parts only.
5. Never mow while barefoot or wearing open sandals or thongs. Wear long trousers and heavy shoes. It is also important to wear suitable eye and hearing protection.
6. Before using, check that the stone guard provided by the manufacturer is in good condition and securely fitted. Regularly check all the components on the mower to ensure the machine is in a safe operating condition.
7. A mower operator should be in good physical and mental health and not under the influence of any drug or alcohol which may impair vision, co-ordination or judgement.
8. Petrol is a highly inflammable fuel. If ignited it could cause destruction of property, serious personal injury or death. Refuel outdoors only over a non-flammable surface. Do not smoke while fuelling engine or fuel near a source of ignition such as an electrical switch or a gas hot water heater. Never remove the cap from the fuel tank or add petrol while the engine is running or if the engine is hot, allow it to cool. Remove fuel cap slowly to relieve any tank pressure. Do not overfill the fuel tank. If petrol is spilled do not attempt to start the engine but move the machine away from the area of the spill and avoid creating any source of ignition until any build up of grass and debris is removed from the machine, all trace of the spill is removed and petrol vapours have dissipated.
9. Check for fuel leaks while refueling. If a fuel leak is detected, do not start the engine until the fuel leak is fixed and the spilled fuel is wiped away.
10. Do not operate the engine in a confined space where the poisonous exhaust fumes (carbon monoxide) can collect.
11. Always disengage the cutting blades before starting or stopping the engine. **NEVER** walk in front of the mower when the engine is running, even if the drive clutch is out. Always stop the engine.
12. Do not operate this mower up and down slopes, mow across a slope only. Misjudged footing or disengaging the drive could cause the machine to run back onto the operator or run out of control down the slope. Never operate the mower across a slope steeper than 10 degrees. **BEFORE** attempting to mow on any slope, refer to "Mowing on Slopes" section in this book.
13. Stay alert for holes in the terrain, tree roots and other hidden hazards.
14. Before crossing paths, driveways or other areas foreign to mowers, disengage cutting blades, stop the engine and lift cutter deck to maximum height.
15. Watch out for traffic when operating the mower near roadways. Always mow with the chute safety deflector properly fitted.
16. Disengage the drive and the cutting blades and stop the engine:
 - a. Before refueling.
 - b. Before fitting grass deflector.
 - c. Before removing side grass catcher.
 - d. Before clearing blockages.
 - e. Before inspecting, cleaning or working on the mower.
 - f. After striking a foreign object, then inspect the mower for damage and make necessary repairs before restarting and operating the machine.
 - g. If the machine starts to vibrate abnormally, then inspect immediately.
17. Disengage the cutting blades when not in use or transporting.

18. Do not over-speed the engine or alter governor settings. Excessive engine revs will shorten the life of the engine and may cause damage to components of the mower that could subsequently result in personal injury.
19. Store the mower and the container of mower fuel in a well ventilated room away from naked flames such as may be found in some hot water heaters. Use only an approved container for storing fuel.
20. Do not allow grass, garden debris or grease to build up on the mower, particularly around the engine. These could be a fire hazard.
21. Replace worn or faulty exhaust mufflers.
22. Mow only in good daylight.
23. Walk, never run whilst mowing.
24. Never walk backwards whilst mowing.
25. Replace any unreadable warning or safety decals.
26. Do not lend or sell this mower without the owner's manual.

MOWING ON SLOPES

Exercise extreme caution when mowing on slopes. Slopes are a major cause of loss of control accidents with mowers, severe injury or death could occur.

The manufacturer recommends the single front castor wheel be replaced with the optional dual wheel assembly (GT999) **before** attempting to mow any slope.

Owing to inadequate reaction to hazard times, the large (fast) drive dogs should be replaced with the standard small drive dogs when working on slopes.

Plan a mowing procedure that does not require sudden directional changes or the drive to be engaged or disengaged while on a slope.

Never operate a mower on any slope if it is wet.

A walk-behind mower should only be operated across a slope never up or down. Disengaging the drive clutch or misplaced footing while working up or down an incline could result in the mower rolling back onto the operator or running out of control down the slope.

Before operating on a slope, remove all loose matter, branches, rocks etc. and stay clear of holes, erosion and tree roots etc. Such hazards can cause unexpected and instantaneous stability changes.

Do not use the grass catching attachment on slopes.

Do not mow close to steep drop offs.

If a totally safe mowing procedure cannot be planned before entering a sloping area, then an alternative method of cutting this area, which does not risk the safety of the operator, should be used.

MAXIMUM SLOPES



UPHILL 0°



DOWNHILL 5°



ACROSS 10°

If the operator of this mower is not absolutely certain a slope does not exceed the previous recommendations, the area should not be entered until such time a properly qualified person has assessed and reported on the safety of the area.

Operating Instructions

BEFORE STARTING

FUEL

Top up with clean, fresh, regular UNLEADED petrol only. Do not overfill. Make sure the petrol is free from impurities, particularly water. Do not use stale petrol in your mower. Before removing the filler cap from the fuel tank, wipe or brush clean the area around the cap to prevent any dirt or debris accidentally entering the tank.

ENGINE OIL

Check oil level by positioning the mower on level ground. Wipe or brush clean the area around the dipstick cap, remove the dipstick and wipe clean. Replace the dipstick screwing firmly into position. Remove again and sight the oil level. Fill to the full mark. **DO NOT OVERFILL**. The dipstick must be firmly in place when the engine is running. Refer to the specific engine manufacturers book to confirm oil and oil filter recommendations and the precise method of checking the oil level.

TYRES

Check Pressure 140 Kpa (20 Psi). Do not over inflate.

TO START

Disengage the cutter clutch (OUT). Disengage the drive clutch (DISENGAGE). Turn fuel tap on (if fitted). Set the throttle control to CHOKE. To start a manual/recoil start engine, grasp the rope handle and pull slowly until resistance

is felt, then pull the cord rapidly to start the engine. If the engine does not start after three attempts, repeat the procedure with the throttle control in the FAST position (no choke). For an electric start model turn the key to the START position for five seconds. If the engine does not start shift the throttle lever to the FAST(no choke) position and try again. Ensure the key returns to the RUN position when the engine starts or after each attempt to start. Allow the engine to warm for a minute before heavy work.

TO STOP

Disengage drive (DISENGAGE). Reduce engine speed (shift throttle control to SLOW). Disengage blade clutch (cutters OUT). Allow engine to cool down by idling approximately 1 minute before stopping. For a manual/recoil start mower, slide throttle control to STOP. For an electric start model, turn the key to STOP. Turn fuel tap off.

EMERGENCY STOP – Electric start models, turn key to **STOP**. Manual start models shift throttle lever to **STOP**.

TO OPERATE

DRIVE

This Greenfield industrial slasher can be operated with or without the drive engaged. The drive engagement lever is located on the console panel between the upper handle bars. Shift the lever up and into the catch to disengage the drive. Shift the lever out of the catch and down to engage the drive. The drive should be disengaged before making sharp turns or attempting to slow the forward speed of the mower. When mowing large, regularly mown areas the larger drive dogs can be fitted to increase the ground speed of the mower. Refer to DRIVE DOGS in the MAINTENANCE section of this book.

CUTTING HEIGHT

The height adjustment lever is located on the left side of the engine. Shift the lever out and forward to select a lower cutting height or out and rearward to select a higher cut.

CUTTING BLADES

The cutters engage lever is located on the right side of the engine. Shift the lever out of the rear catch and into the front catch to engage the cutting blades. Reverse this action to disengage the cutting blades.

THROTTLE CONTROL

The throttle control lever is located on the left side of the control console. This lever incorporates the CHOKE control for cold starting as well as the adjustment for engine revs SLOW to FAST. It also has the STOP function for manual/recoil start engines only. The stop function for an electric start model is incorporated in the key start switch.

ELECTRIC START

Electric start models have a key turn starter switch mounted in the control console. Turn key to OFF to stop engine. Refer to "TO START" in this book for details of the switches other functions

BATTERY (if fitted)

To maintain the correct fluid level in the battery, top with distilled water only to the high level mark shown on the battery.

Note: If the mower is not used for at least 5 hours a month the battery will discharge and could sustain permanent damage. Do not allow the battery to discharge. Regularly trickle charge with a current not exceeding 3 amps per hour for 3 to 4 hours to prolong battery life. Keep the outside of the battery, especially the terminals, clean and dry and check the battery is held securely.

The maintenance of the battery is the owners responsibility. Only faulty batteries are covered by warranty. Neglect is not covered.

Dry Battery: When initially charging a new DRY battery, each cell must be filled to the high level shown on the battery with an electrolyte (dilute sulphuric acid) with a specific gravity of 1.26 at 20°C to 30°C. The battery must then be allowed to stand for 30 minutes before charging at a rate not exceeding 3 amps for 4 hours.

Warning: Persons not trained in the proper procedure to transfer fluids containing acid or do not have the necessary safety equipment on hand in case of a spill or exposure, should not attempt this procedure. Contact the battery manufacturers local agent or an authorized Greenfield dealer.

MAINTENANCE

LUBRICATION

Change the engine oil after the first 5 hours of operation then every 6 months or 25 working hours, whichever comes first. Change more often in heavy work or dusty conditions. Drain engine oil whilst engine is warm then replace with a high quality SAE 30 detergent oil classified for service SF/SG. Fill to the full mark indicated on the dipstick. Do not overfill. Refer to the specific engine manufacturers book to confirm oil and oil filter recommendations and the precise method of checking the oil level.

The components of the gearbox have been lubricated prior to the gearbox being sealed at the factory. The shafts run in large sealed ball bearings. No further lubrication of the gearbox is required.

Lubricate all other pivoting joints, lever points and slides with engine oil.

AIR FILTER

Service the air filter as per the specific engine manufacturers book. Clean or replace more often in dusty conditions. Never operate the engine without the air filter correctly and securely fitted, rapid and expensive wear will occur.

DRIVE DOGS

There are two sizes supplied. The smaller set is for slow speed, heavy grassed areas, confined or uneven areas. The larger set is for basically flat, larger, regularly mown areas. To change the drive dogs, disengage the drive, stop the engine and remove the spark plug lead to prevent accidental starting. Remove the nyloc nut and washer from the end of both drive shafts and slide off the drive dogs. Fit the new drive dogs onto the drive shafts making sure that the recess in the end of the dogs engages over the pins in the drive shaft. Refit the washers and the nyloc nuts.

TYRES

Check pressure 140 Kpa (20 psi). Do not over inflate.

COOLING SYSTEM

Debris may clog the engines air cooling system. Remove the blower housing and clean out grass and debris to prevent overheating and engine damage. Refer to manufacturer's booklet.

CLEANING

Clean off all grass and other debris before storing. Sticks, stones or an accumulation of grass and other debris will damage belts and fracture pulleys if they go through between the pulley and belt. When operating in these conditions the cutter deck may require more frequent cleaning.

Never wash your Greenfield with a high pressure wash gun. Water and dirt could bypass the seals in the bearings causing premature bearing failures and rusted pivot points.

Allow your Greenfield to cool after use. The quenching contraction effect from hosing the machine when it's at operating temperature could also draw water and dirt into the bearings.

The best way to clean your Greenfield is to use a low pressure air hose or garden blower to blow the loose grass etc from around pulleys, belts and the top of the cutter deck. Wash the exterior the same as you would your car. For maximum machine life, do not spray water on the engine, pulleys and bearings. Re-oil all pivots after wash.

BLADES

Check the condition of the blades, blade bolts and the blade holder.

Replace if damaged or worn. Worn or damaged blades or blade bolts are a major hazard. Always replace worn or damaged blades and bolts in sets to preserve balance.

Use only **GENUINE GREENFIELD** replacement parts.

Use of inferior non-genuine replacement parts on your Greenfield mower could result in costly damage or even personal injury.

The part number for

CUTTER BLADES & BOLTS SET: GT 2141

To fit new blades refer to illustration A.

Tighten the blade bolt nut firmly. Correct torque is 44 Nm (32 ft.lbs). Blades must be free to move but not loose. Lightly oil the blade pivot point before fitting.

V BELTS

Inspect both V belts and replace if damaged or worn. Both the drive belt and the cutter belt on your Greenfield slasher mower have automatic tension adjusters. Lubricate the sliding and pivoting mechanisms of these adjusters regularly.

The part numbers for V belts are: **DRIVE V BELT: GT 2336**
CUTTER V BELT: GT 2337

Important: For long service life, use only **genuine GREENFIELD** branded V Belts. Refuse substitutes.

To change the Cutter Belt:

1. Remove the spark plug lead to prevent accidental starting.
2. Disengage the blade clutch and drive clutch.
3. Remove the front cover.
4. Remove the belt guide from the engine pulley.
5. Remove the belt guide from the cutter pulley.
6. Support the weight of the cutter deck then disconnect the lifting chain.
7. Remove the belt from both pulleys and replace with a **genuine Greenfield GT 2337** cutter belt
8. Refit the lifting chain, belt guides and cover.
9. Replace the spark plug lead.

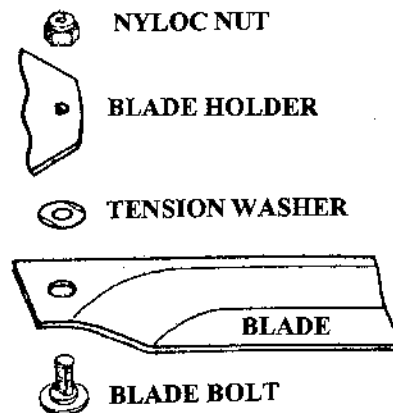
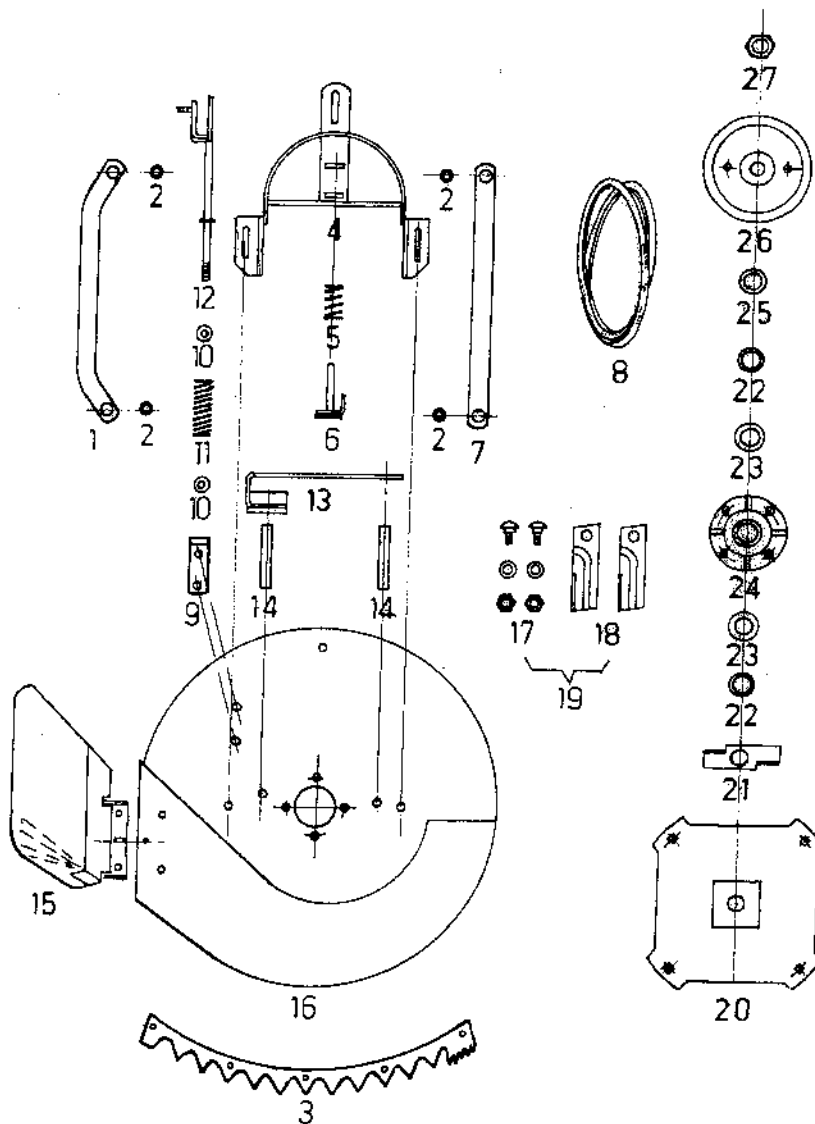

Illustration A

CUTTER DECK



INDEX	PART NO	DESCRIPTION	INDEX	PART NO	DESCRIPTION
1.	GT 4005A	Link - Right Hand	15.	GT 4295	Stone Guard
2.	GT 730	Pivot Bush	16.	GT 4301	Cutter Deck
3.	GT 4344	Foot Guard	17.	GT 2110	Bolt Set
4.	GT 4360	Frame	18.	GT 2140	Blade Set
5.	GT 1867	Spring - Compression	19.	GT 2141	Blade and Bolt Set
6.	GT 4102	Cutter Brake Unit	20.	GT 9530	Disc Assembly
7.	GT 4005	Link - Left Hand	21.	GT 8205	Wiper
8.	GT 2337	V Belt - Cutters	22.	GT 20177	Spacer
9.	GT 4314	Bracket	23.	GT 539	Shim
10.	GT 585	Cup Washer	24.	GT 7988	Spindle Housing Unit
11.	GT 14022	Spring - Compression	25.	GT 5089	Spacer - Pulley
12.	GT 4315	Cutter Clutch Rod	26.	GT 402	Pulley
13.	GT 4099	Belt Guide	27.	GT 328	Nut
14.	GT 4093	Post			

PARTS AND SPECIFICATIONS SUBJECT TO CHANGE WITHOUT NOTICE
STANDARD HARDWARE ITEMS ARE NOT SHOWN OR LISTED.

To Change the Drive Belt

1. To remove the drive belt, the cutter belt must first be removed from the engine pulley. Follow step numbers 1 to 4 of "To change the Cutter Belt" then drop the cutter belt from the engine pulley only.
2. Release the tension spring from the drive belt idler pulley and slide the pulley back.
3. Remove the drive belt from the pulleys and replace with a **genuine Greenfield GT2336** drive belt.
4. Replace the tension spring to the idler pulley.
5. Replace the cutter belt onto the engine pulley, replace the engine belt guide and cover.
6. Replace the spark plug lead.

HANDLES, CONTROLS & COVERS

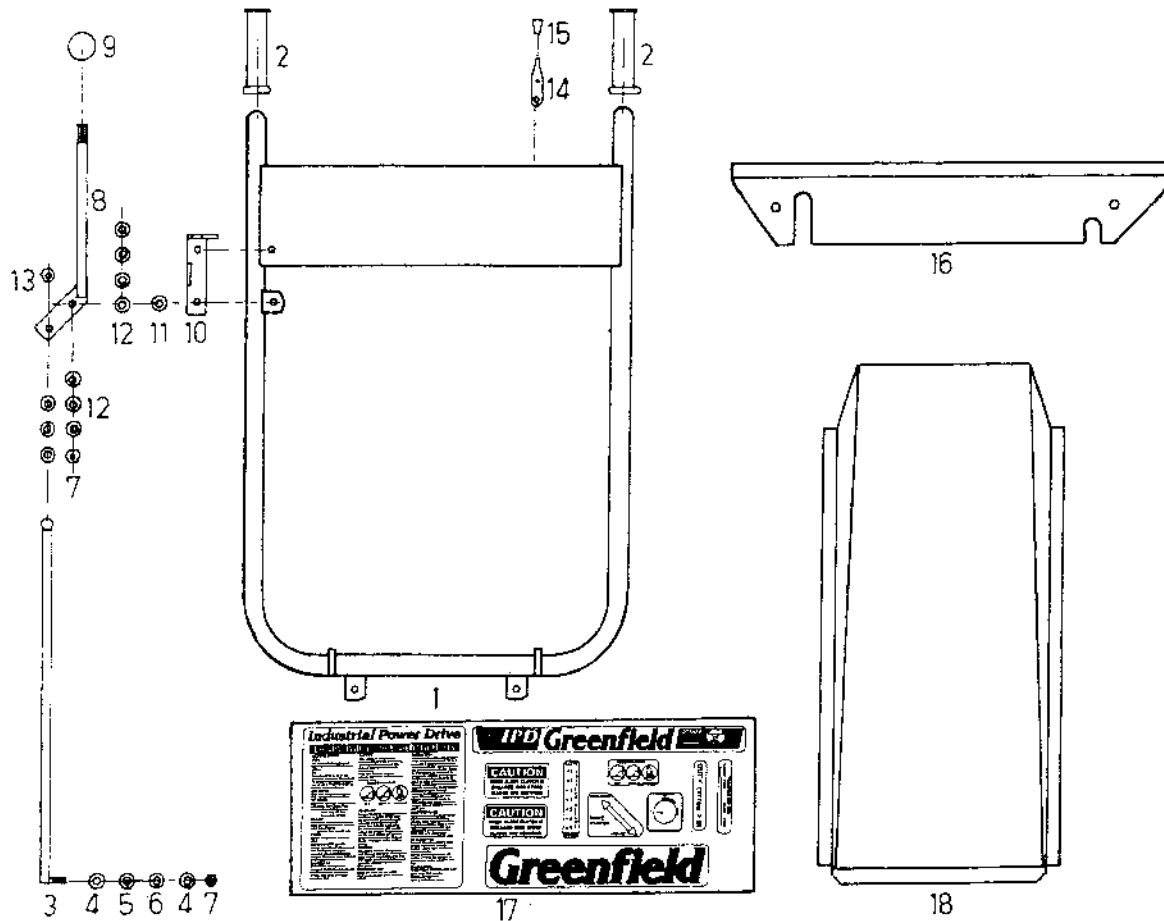

INDEX	PART NO	DESCRIPTION
-------	---------	-------------

1.	GT 4335	Handle Bar Assy
2.	GT 757	Hand Grip
3.	GT 4325	Rod - Drive
4.	GT 1012	Washer
5.	GT 579	Wave Washer
6.	GT 730	Pivot Bush
7.	GT 2466	Nyloc Nut
8.	GT 4330	Lever - Drive
9.	GT 1565	Knob

INDEX	PART NO	DESCRIPTION
-------	---------	-------------

10.	GT 4324	Latch
11.	GT 10037	Bush
12.	GT 1567	Belville Washers
13.	GT 2413	Nyloc Nut
14.	GT 20169	Throttle Lever
15.	GT 2026	Knob
16.	GT 4043	Drive Shaft Cover
17.	GT 4356	Decal Set
18.	GT 697	Front Cover

**PARTS AND SPECIFICATIONS SUBJECT TO CHANGE WITHOUT NOTICE
STANDARD HARDWARE ITEMS ARE NOT SHOWN OR LISTED.**

ENGINE, FRAME & WHEELS

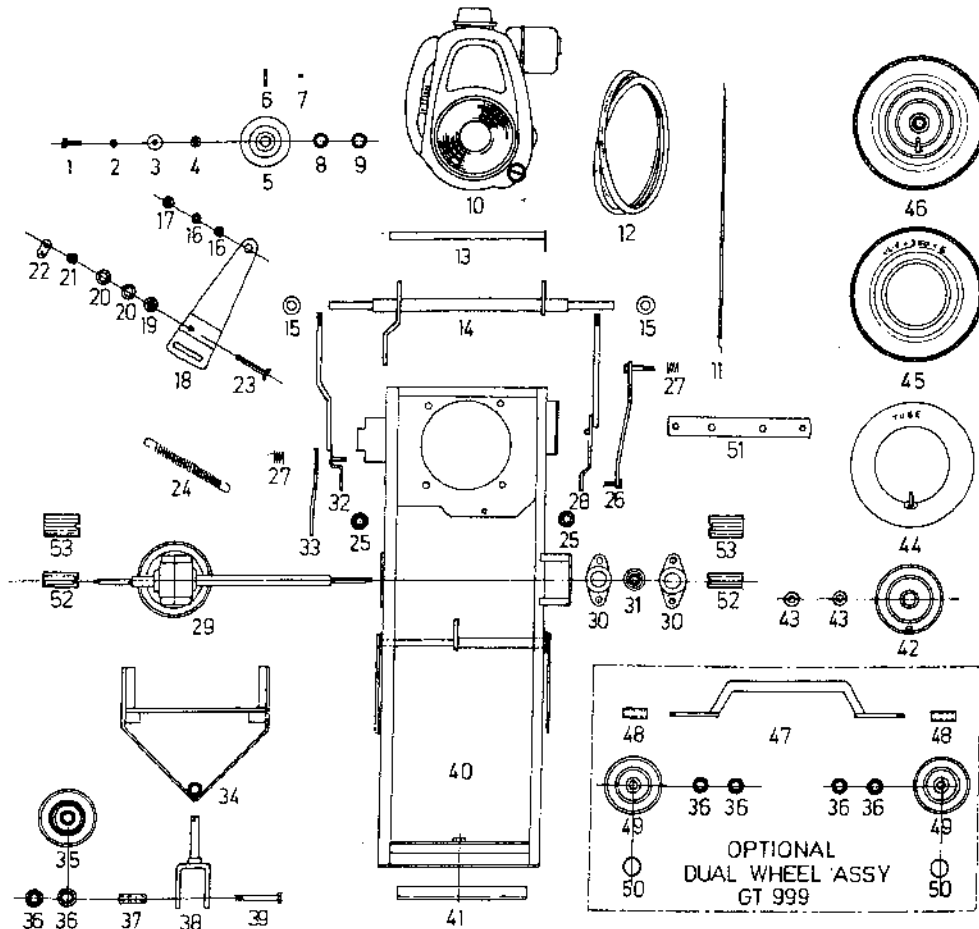

INDEX PART NO DESCRIPTION

INDEX	PART NO	DESCRIPTION
1.	GT 1069	H.T. Bolt
2.	GT 2021	Spring Washer
3.	GT 1750	Flat Washer
4.	GT 12022	Extension
5.	GT 731	V Pulley
6.	GT 1500	Key
7.	GT 520	Grub Screw
8.	GT 1501	Spacer
9.	GT 1182	Spacer
10.		Engine as fitted
11.		Throttle Cable
12.	GT 2336	V Belt Drive
13.	GT 693	Pivot Rod Assy
14.	GT 4345	Axle Assy
15.	GT 628	Collar
16.	GT 2046	Crinkle Washer
17.	GT 608	Spacer
18.	GT 4304	Belt Tensioner Arm
19.	GT 23043	Bearing Adaptor
20.	GT 396	Bearing
21.	GT 1012	Washer
22.	GT 5056	Spring Tag
23.	GT 1118	Bolt
24.	GT 749	Spring
25.	GT 1179	Bush - Axle
26.	GT 4282	Link
27.	GT 7071	Spring - Compression

INDEX PART NO DESCRIPTION

28.	GT 4285	Height Adjust Lever
29.	GT 4080	Gear Box & Shaft Complete
30.	GT 760P	Flangette Plate
31.	GT 760	Bearing
32.	GT 4305	Cutter Clutch Lever
33.	GT 4311	Link
34.	GT 4076	"A" Frame
35.	GT 1864	Wheel Complete
36.	GT 1179	Bush
37.	GT 1899	Sleeve
38.	GT 4075	Fork Assy
39.	GT 1155	Bolt
40.	GT 4355	Frame
41.	GT 4070A	Clamping Bar
42.	GT 2233	Wheel Hub
43.	GT 398	Bearing
44.	GT 454	Tube
45.	GT 453	Tyre
46.	GT 912	Complete Wheel
47.	GT 4100	Axle
48.	GT 739A	Sleeve
49.	GT 4069	Wheel Complete
50.	GT 1930	Hub Cap
51.	GT 4280	Belt Guide
52.	GT 728	Drive Dog Small
53.	GT 732	Drive Dog Large

**PARTS AND SPECIFICATIONS SUBJECT TO CHANGE WITHOUT NOTICE
STANDARD HARDWARE ITEMS ARE NOT SHOWN OR LISTED.**

GUARANTEE

Greenfield Mowers Pty Ltd, the manufacturer, guarantee their product to be free of faulty workmanship and material for a period of 12 months for domestic use, 3 months for commercial use from the date of purchase to the original owner. The guarantee for this Greenfield IPD slasher covers machines in domestic or owner operated commercial use only. Mowers hired out are not covered by the manufacturers guarantee. Engines and batteries used on Greenfield mowers carry the respective manufacturers warranty.

This guarantee will not apply to:

- Fair wear and tear, V Belts, Tyres, Tubes, Blades and blade Bolts, Blade Holder, and damage caused by misuse, neglect and accidents.
- Repairs rendered necessary or arising from use of other than genuine Greenfield parts, or the relevant genuine manufacturers parts.
- Any work performed by other than an authorised Greenfield Dealer, or damages arising therefrom or parts that have been tampered with or dismantled.

To claim warranty on the Greenfield IPD the customer must return the mower intact to an authorised Greenfield Dealer. In all warranty claims the manufacturer's decision is final and binding.

The benefits conferred by the above guarantee are in addition to all other rights and remedies in respect of the product which the consumer has under existing laws in Australia and New Zealand. Greenfield Mowers Pty Ltd, the manufacturer reserves the right to change parts and specifications without notice.

Guarantee Registration Details

Owner _____

Address _____

_____ Postcode _____

Purchase Date ____ / ____ / ____ Model _____

Chassis No. _____ Engine Serial/ Batch No. _____

Dealer Name _____

Dealer Signature _____

This record should be completed and held by the purchaser and presented should service under guarantee be required. To register your guarantee please complete the enclosed guarantee card and return to Greenfield Mowers.

Greenfield
Mowers Pty Ltd

172 Ingram Rd, Acacia Ridge, Qld. Australia 4110.

PO Box 155 Archerfield QLD 4108

Fax (07) 3344 1161. Phone (07) 3345 6100

Web Site: <http://www.greenfield.com.au> - Email: greenfld@gil.com.au